

MapleArashi

Fiber Optic Cable Manufacturer

Outdoor Self-Supporting FTTH Drop Cable - GJYXCH

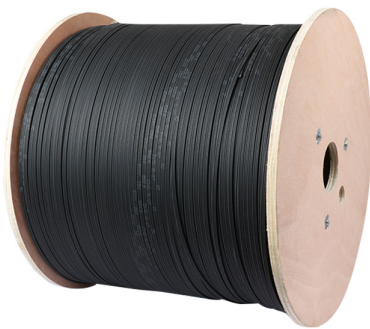

Cable Structure - GJYXCH

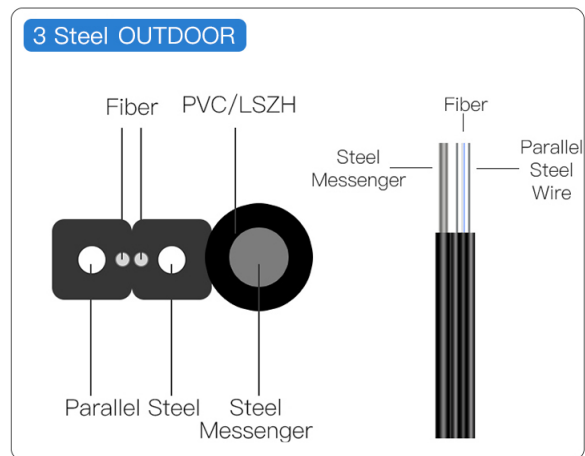

GJYXCH Outdoor Self-Supporting FTTH Drop Cable Self-Supporting FTTH | Steel Messenger | Steel Wire Strength Members

[Outdoor Self-Supporting FTTH](#) | [Steel Messenger](#) | [Steel Wire Strength Members](#)

GJYXCH is an outdoor self-supporting FTTH bow-type drop cable designed for aerial subscriber access, outdoor-to-indoor routing, and terminal connection applications. The cable combines a compact bow-type drop cable body with two parallel steel wire strength members and a steel messenger for self-supporting aerial drop installation. Final cable parameters, sheath material, strength member design, messenger design, and installation span are subject to project requirements and confirmed cable design.

Product	GJYXCH
Model	GJYXCH
Category	FTTH Drop Cables - Outdoor Self-Supporting Drop Cables
Structure	Self-supporting bow-type FTTH drop cable with steel messenger and steel wire strength members

This specification is for reference only. Final cable design parameters are subject to project requirements and manufacturing feasibility.

1. Product Information

Field	Specification
Product	GJYXCH
Model	GJYXCH
Category	FTTH Drop Cables - Outdoor Self-Supporting Drop Cables
Structure	Self-supporting bow-type FTTH drop cable with steel messenger and steel wire strength members
Fiber Type	G.657A1 / G.657A2 / G.652D; subject to project requirements
Number of Fibers	Subject to final cable design and project requirements
Internal Strength Member	Two parallel steel wires, subject to final cable design
Messenger / Support Mem	Steel messenger, subject to final cable design and span requirements
Sheath Material	PVC / LSZH or project-specified sheath, subject to project requirements
Sheath Color	Subject to project requirements
Application	Aerial FTTH subscriber access / outdoor-to-indoor drop / terminal connection

2. Company Profile

Maplearashi Technology, with 20 years of expertise in fiber optic communication, manufactures GJYXCH outdoor self-supporting FTTH bow-type drop cables with steel messenger and parallel steel wire strength members in our facility located in the Guangdong-Hong Kong-Macao Greater Bay Area. The integrated messenger design facilitates aerial drop installation for fiber-to-the-home subscriber access networks. Compliance documents available upon request.

3. Product Overview

GJYXCH is an outdoor self-supporting FTTH bow-type drop cable designed for aerial subscriber access, outdoor-to-indoor routing, and terminal connection applications. The cable uses a figure-8 cross-section with a compact bow-type drop cable body connected to a steel messenger, supported by two parallel steel wire strength members inside the drop cable body. This design enables single-span aerial drop installation without additional lashing or support hardware, subject to project requirements and confirmed cable design.

4. Key Features

- Outdoor self-supporting bow-type FTTH drop cable for aerial subscriber access applications
- Integrated steel messenger for self-supporting aerial drop installation
- Two parallel steel wire strength members inside the drop cable body
- Figure-8 cross-section design combines messenger and drop cable body
- Available in G.657 bend-insensitive fiber types for tight routing
- Compatible with standard FTTH field termination and connectorization solutions

5. Recommended Use

- Aerial FTTH subscriber access from distribution point to building entrance
- Self-supporting drop installation from pole to residential or commercial premises
- Outdoor-to-indoor FTTH drop routing with appropriate transition hardware
- Residential FTTH aerial access in urban, suburban, and rural deployments

6. Installation Benefits

- Integrated messenger reduces installation time compared to lashed or ducted drop cables
- No external messenger or lashing hardware required for short-span aerial installation
- Compact bow-type drop cable body for easy termination at premises
- Steel messenger provides robust self-supporting capability for aerial FTTH drop routes

7. Technical Specifications

7.1. Cable Structure

Layer	Component	Material / Function
1	Optical Fiber	G.657A1 / G.657A2 / G.652D; subject to project requirements
2	Internal Strength Member	Two parallel steel wires, subject to final cable design
3	Drop Cable Body	Bow-type flat construction
4	Messenger / Support	Steel messenger, subject to final cable design and span requirements
5	Outer Sheath	PVC / LSZH or project-specified sheath, subject to project requirements

Material and design details can be adjusted according to fiber type, count, and project needs.

8. Applications

- Aerial FTTH subscriber access from pole to building entrance
- Outdoor-to-indoor FTTH drop connection with appropriate transition hardware
- Residential FTTH aerial access in urban and suburban deployments
- Short-span aerial drop routes where self-supporting FTTH drop cable is required
- Outdoor wall-mount drop routing with messenger anchoring

9. Design Notes

- Mechanical parameters, span length, and installation tensions subject to final cable design
- Designed for outdoor aerial self-supporting installation per project requirements
- GJYXCH uses steel messenger. GJYXFCH uses non-metallic support direction depending on design.
- GJYXCH is an outdoor self-supporting FTTH drop cable, not an indoor drop cable.
- GJYXCH is not ADSS all-dielectric self-supporting cable for long-span transmission.
- GJYXCH is not a Figure-8 loose tube cable. GYTC8S and GYXTC8S are Figure-8 loose tube cable family.

10. Aerial Installation Notes

- Maximum installation span depends on messenger wire diameter, cable weight, loading conditions, and project-specific requirements
- Proper tensioning of the messenger is essential for correct sag performance
- Use appropriate messenger anchors and hardware designed for self-supporting FTTH drop cables
- Installation temperature and pulling tensions subject to project-specific cable design
- Avoid sharp bending of the flat drop cable body during aerial routing and entry into premises
- Transition hardware may be needed at the outdoor-to-indoor entry point

11. Handling & Termination Notes

- Use proper stripping tools for bow-type drop cable body
- Separate messenger from the drop cable body at termination points as required
- Avoid twisting or sharply bending the cable during installation
- Confirm fiber type and sheath color before batch production
- Suitable for field connector, pigtail, or terminal box installation at the premises side

12. Fiber Options

Fiber Type	Description
G.652D	Standard single-mode fiber — ITU-T G.652.D standard
G.657A1	Bend-insensitive fiber — ITU-T G.657.A1 standard
G.657A2	Enhanced bend-insensitive fiber — ITU-T G.657.A2 standard
Custom	Other fiber types available per project requirements

13. Installation Guidance

- Installation temperature and pulling tensions subject to project-specific cable design
- Minimum bend radius during installation: refer to project-specific datasheet
- Outdoor aerial installation with integrated steel messenger for self-supporting short-span drop
- Compatible with standard FTTH termination and splicing procedures at premises side

14. Model Comparison & Reference

GJYXCH vs GJXH

Parameter	GJYXCH	GJXH
Type	Outdoor self-supporting FTTH drop	Indoor bow-type FTTH drop
Messenger	Steel messenger	None
Strength Member	Steel wires	Steel wires
Application	Aerial drop / outdoor to indoor	Indoor wall / conduit routing
Note	Self-supporting aerial vs indoor-only	See separate GJXH specification

GJYXCH vs GJYXFCH

Parameter	GJYXCH	GJYXFCH
Type	Outdoor self-supporting FTTH drop	Outdoor self-supporting FTTH drop
Messenger Direction	Steel messenger	Non-metallic support direction depending on design
Strength Member	Steel wires	Subject to final cable design
Note	Steel messenger variant	Non-metallic variant; see separate GJYXFCH specification

GJYXCH vs GYTC8S / GYXTC8S

Parameter	GJYXCH	GYTC8S / GYXTC8S
Cable Family	FTTH drop cable	Figure-8 loose tube cable
Messenger	Steel messenger	Integrated messenger (loose tube design)
Fiber Count	Low fiber count	Up to higher fiber counts
Application	Aerial FTTH subscriber drop	Distribution / feeder aerial backbone
Note	Drop vs backbone cable	See separate GYTC8S specification

15. Customization Options

- Fiber type and count per project requirements
- Sheath color and marking per project requirements
- Alternative sheath materials subject to project requirements
- Messenger diameter and design subject to span and loading requirements
- Sheath marking, meter marking, and cable color
- Drum length and packaging per project or shipping requirements

Maplearashi

MapleArashi | maplearashi.com

Email: sales@maplearashi.com | WhatsApp: +86 189 9307 0653

Shenzhen Maplearashi Technology Co., Ltd. | Guangdong-Hong Kong-Macao Greater Bay Area, China